

# Termodin/air\

## Information about DELTALIGHT



Large illustration: DELTALIGHT with NSHE units type PHOENIX NSE wings.



DELTA LIGHT on a productionhall ...



... with integrated NSHEVs Typ PHOENIX



Asymmetrical DELTA LIGHT

## Information about DELTALIGHT

The DELTALIGHT is a triangular skylight system on a self-supporting aluminium construction in which multiwall polycarbonate panels are inserted. Due to its design with glazing elements mounted in extruded aluminium sections, the DELTALIGHT has good thermal-insulation properties, thus guaranteeing low energy costs. Significantly better insulation values can be achieved by filling the panels with Lumira™ aerogel. The Lumira™ also results in excellent light-scattering properties. Installing or retrofitting natural smoke and heat extractors or other devices into the DELTALIGHT is an easy option. The DELTALIGHT system can be fitted with a PSP30 fall-through prevention system. It is adapted accordingly for special requirements such as stricter sound insulation standards. Furthermore, south-facing solar shading can be installed.

The DELTALIGHT is available in both the MKI and the MKII versions. The two versions have different base profiles. The MKI profile permits the angles to differ allowing an asymmetrical construction up to a width of two meters. Furthermore, it is easier to install. The more economic MKII base profile is only available in two versions with either a 30° or a 45° fixed angle.

The DELTALIGHT complies with the fire classification B-s1, d0 (opal: B-s2, d0).

### Advantages:

- Natural daylight (glare-free when Opal or Lumira™ aerogel filled panels are fitted)
- Natural smoke and heat extractors can be fitted which can also be used for everyday ventilation
- Low weight due to aluminium sections and multiwall polycarbonate panels
- Optimum sun-protection louvres reduce heat build-up in the building in summer'
- Simple assembly in a modular system

Standard-angle sequence 45° / 90° / 45° and 30° / 120° / 30°  
Other angle sequences and asymmetrical construction (up to 2m)  
possible by request.

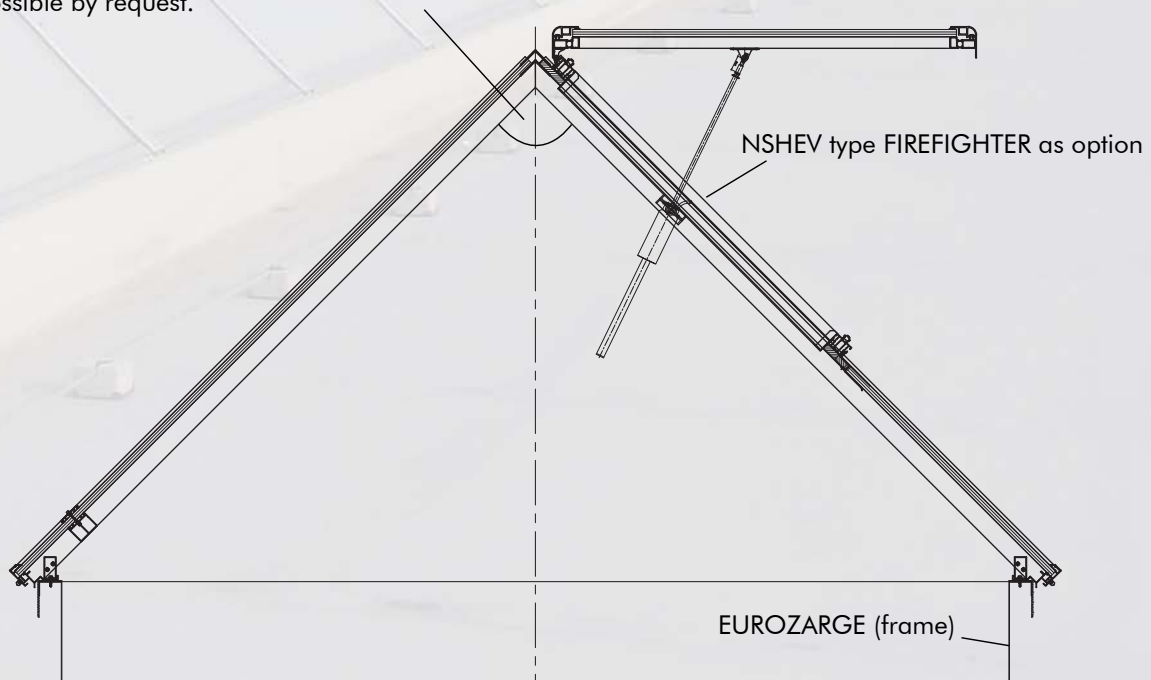

DELTALIGHT with integrated PHOENIX natural smoke and heat extractor.

## Information about DELTALIGHT

### Design characteristics:

The self-supporting construction is made of the aluminium alloy AlMg Si05 F22. Here, the base edge profile is mounted on a curb. At the end faces the glazing elements are held in an all-round end-panel profile. The profile ends are cut to the same angle as the first and last end-panel glazing bars, and at the same time they form the border of the base. The end panel is made of 16 mm multiwall polycarbonate panel. Threaded glazing bars welded together form the ridge turrets and the basis for the infill. The ridge flashing is made up of ridge caps and angle plates, which are attached to the upper glazing bars. All fittings are made of aluminium or stainless steel.

### Sizes:

The DELTALIGHT is manufactured for roof openings between 1,500 mm and 5,000 mm. With a glazing bar spacing of 1,000 mm, there are no length restrictions. The skylight is available with the following standard angle combinations: 30°/ 120°/ 30° and 45°/ 90°/ 45° mm. Asymmetrical designs and other angles are available on request.

### Infill:

The glazing infill is made of multiwall polycarbonate panels with a choice between different thicknesses, with or without Lumira filling. An insulated-glass infill is also available.

Light and thermal transmittance values of the polycarbonate multiwall panels:

Plate thickness (for transparent multiwall panels)	Light transmission in %	U-value in W/m <sup>2</sup> K
10 mm	65%	2.39
+ Lumira™	65%	1.93
16 mm	59%	1.82
+ Lumira™	57%	1.31
20 mm	58%	1.67
Lumira™ not available		
25 mm	40%	1.50
+ Lumira™	32%	0.89
32 mm	48%	1.10
Lumira™ not available		

For glare-free lighting, the panels are also available in an opal version. This option is not available for Lumira™-filled panels as Lumira™ aerogel already provides for optimum light-scattering characteristics.



## Information about DELTALIGHT

### End-panels:

The end panels are manufactured out of custom-made polycarbonate multiwall panels. The panels are held in place by the upper and lower end-panel profiles. The upper end-panel profile is held in place by the upper and lower glazing bars. The lower end-panel profile serves as the base profile.

